

Technical Data Sheet OPUS A8 STANDARD Basic



1 Notes and Warnings

⚠ Attention!

This description is not a substitution for the concerned product's documentation. Please do read the documentation including the manuals carefully before dealing with this product. If the safety instructions in the documentation are not followed dangerous situation can occur that can result in damages, injuries and/or death by high voltage or wrong handling. In case you do not have the correct documentation you can order it by contacting dl-opus-info@topcon.com. Only properly trained personnel with the correct qualification are allowed to handle the device.

⚠ Attention!

Do not open the housing to avoid danger to high voltages. Before touching the electric assemblies make sure that the electricity is switched off completely. If the front pane is broken the device needs to be taken out of service due to risk of injury. If perceivable damages on the device exist that can compromise the functionality, it must be taken out of service due to the danger of malfunctions. These particularly include damages to the LCD display, damages to the keyboard, damages that compromise the protection level and damages to the encoder knobs.

Please note:

All content is subject to change without notice. Errors and omissions excepted.

Mounting and Handling

1. Do not use the cable as a handle to carry the device.
2. Mounting in clean working environment only. Dust and oil can harm the electric contacts and compromise the functionality.
3. Do not mount the device under the use of violence because it can cause damage.
4. The device must be mounted by trained personnel only into especially designed and tested systems.
5. The device must not be opened or disassembled.
6. The device is to be cleaned with a moist fuzz free cotton cloth. If necessary a mild cleaning agent can be used. Do not use acid or abrasive cleaning agents.
7. The device is to be stored in a cool and dry environment and to be protected against sun shine.
8. If the environmental temperature is beneath 10°C the reaction time of the display increases.

2 General Information

Order Numbers

This documentation is valid for **OPUS A8** order numbers as follows:

	OPUSA8SN1CANB000	OPUSA8SN1CDSB000	OPUSA8SN1ISOB000
OPUS Projektor	•		
CoDeSys		•	
ISO-VT			•

Dimensions

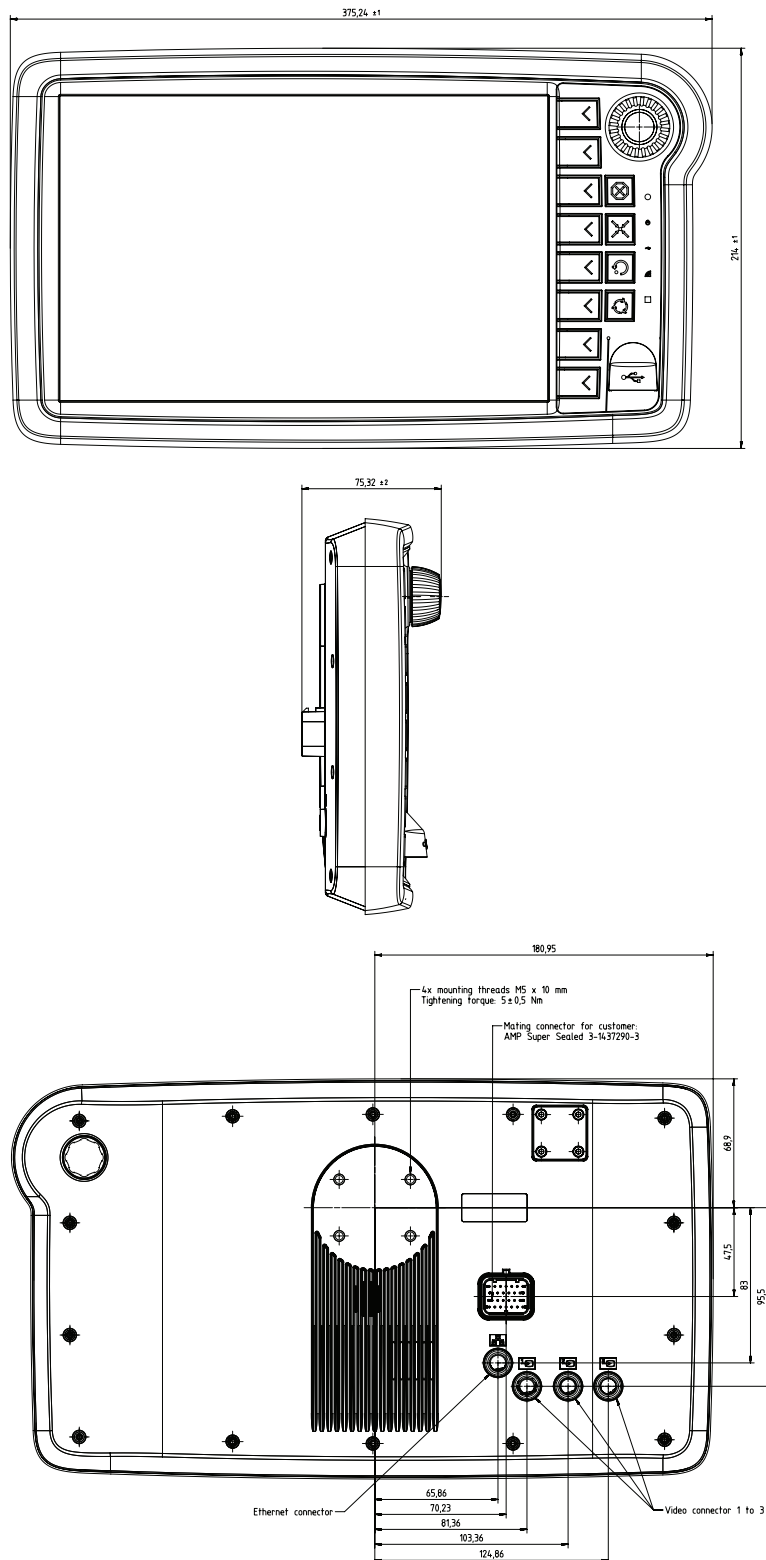

Housing

Aluminium back-housing, plastic front-housing, colored light grey (RAL 7035) with black rubber frame.

Mounting

- Landscape or portrait
- Standalone
- In-dash

3 Display

Type:	TFT Color Graphic LCD with LED backlight	Colors:	16,7 Mio
Size:	12.1", 261 mm (W) x 163 mm (H)	Brightness:	typ. 400 cd/m ²
Resolution:	1280 x 800 px (WXGA), 16:10	Contrast Ratio:	typ. 1,000:1

4 Input Devices

Touch PCT

Right Keypad

- 8+4 keys with tactile feedback
- Multicolor-LED backlight
- Lifetime 1.000.000 actuations

Indicators and Sensors

- Light sensor
- 1 Multicolor-LED
- 3 Status-LED's

Encoder

- Optical encoder with 16 mechanical detents and push function
- Lifetime: 1 million cycles

5 Electronics

Processor platform

CPU: Freescale I.MX6®, solo core, 800 MHz
 Mass storage: 4 GByte
 RAM: 512 MByte
 RTC: Buffered by gold cap

Speaker • 80 dB(A) in 1m distance @ 1kHz

Power supply

Operating voltage range: 9 ... 36 V DC
 Protection: Short circuit protection
 Overvoltage resistance: 48V for max. 5 minutes
 Inverse polarity protection: Up to -48 V DC for max. 5 minutes

Current consumption (without external load), max.

Power Mode	Current at 13,5 V DC	Current at 27 V
On	≤ 1,6 A	≤ 0,7 A
Low-power	Depending on config	
Sleep	≤ 0,2 A	≤ 0,1 A
Off	≤ 2 mA	≤ 4 mA

6 Interfaces

CAN Bus

- 2 x CAN-Interfaces
- ISO 11898, CAN-specification 2.0 B active
- Up to 1 Mbit/s (default 250 Kbit/s, 500 Kbit/s, 750 Kbit/s and 1 Mbit/s)

RS232

1 x RS232-Interface
 Type: EIA232 (only Rx/D, Tx/D, GND)
 Speed: max. 115 Kbps

USB

Main connector: 1 x High speed
 On front: 1 x USB slot High speed

Inputs

2 configurable analog/digital inputs
 Input impedance: > 3k Ohm
 Resolution: 10 bit (1024 digits,
 1 digit = 11,7 mV)
 Input range: 0 ... 12V, 4-20 mA, 0-20 mA
 Max. protectable
 input voltage: 36 VDC
 Protection: Short circuit protection
 Frequency: Max. signal frequency
 50 Hz

Outputs

1 digital output
 Short circuit protection: Up to 36 V
 I_{max} : 300 mA open drain at 12V
 $R_{DS,on}$: < 1 Ohm
 $R_{DS,off}$: > 100 kOhm

Audio

- 1 x Audio output (left, right, GND)
- AC97 compatible
- Output power: approx. 65 mW @ 32 Ohm

Video-Interface

Inputs: 1 x analog (1 live stream)
 V_{ss} : 1 V
 Camera supply: 12 VDC
 Max. current: 500 mA
 Output: 1x camera control output
 (open drain) for special
 functionality
 (mirror, shutter, heating
 etc.)
 Ampacity 300 mA

Ethernet-Interface

1 x 10/100 Mbit/s Base T

7 Connectors

Connectors

Main: Tyco-AMP 3-1437290-7
 Video: M12 round connector, female, 5-pole,
 B-coded acc. to EN 61076-2-101
 Ethernet: M12 round connector, female, 4-pole,
 D-coded acc. to EN 61076-2-101

8 Software

Operating System Linux Kernel 3.0.0 or higher

Application Programming • OPUS Projektor
 • Codesys-Tools (3.X)
 • ISO-VT
 • C/C++

9 Testing and Verification

CE-Compliance

EU Directive 2014/30/EC (EMC) according to

- *EN 13309: Construction machinery – Electro-magnetic compatibility of machines with internal electrical power supply*
- *EN ISO 14982: Agricultural and forestry machinery - Electromagnetic compatibility - Test methods and acceptance criteria*

E1 - Type approval

EU Directive ECE R10

Protection Level (IP Code)

IP 65 and IP 66 according to *ISO 20653: Road Vehicles – Degrees of protection (IP-Code) – Protection of electrical equipment against foreign objects, water and access*

Electrical

12 and 24V-Systems according to:

- *ISO 16750-2: Road Vehicles – Environmental conditions and testing for electrical and electronic equipment – Electrical loads*
- *ISO 15003: Agricultural Engineering – Electrical and electronic equipment – Testing resistance to environmental conditions*

Mechanical

- *According to ISO 16750-3: Road Vehicles – Environmental conditions and testing for electrical and electronic equipment – Mechanical loads, Code L*
- *ISO 15003: Agricultural Engineering – Electrical and electronic equipment – Testing resistance to environmental conditions*
 - *Mechanical Shock: Level 2*
 - *Random Vibration: Level 2*
 - *Sinusoidal Vibration: Level 2*

Climate

- *ISO 16750-4: Road Vehicles – Environmental conditions and testing for electrical and electronic equipment – Climatic Loads*
 - *Operating Temperature Range: -30 ... +65°C*
 - *Storage Temperature Range: -40 ... +85°C*
- *ISO 15003: Agricultural Engineering – Electrical and electronic equipment – Testing resistance to environmental conditions*

10 Pinout

Main connector pinout

Pin. No.	Assignment	Description
1	VCC	supply voltage +; terminal 30
2	Ignition Input	ignition input; terminal 15
3	GND	supply voltage - ;terminal 31
4	CarGND	Car GND
5	NA	NA
6	NA	NA
7	NA	NA
8	CAN1H	CAN 1 high
9	CAN1L	CAN 1 low
10	CAN2H	CAN 2 high
11	CAN2L	CAN 2 low
12	USB_VCC	USB +5V supply
13	USB_GND	USB supply GND
14	USB_D-	USB Data -
15	USB_D+	USB Data +
16	RS232 RxD	RS232 receive data
17	RS232 TxD	RS232 transmit data
18	RS232 GND	RS232 GND
19	NA	NA
20	A/DI1	analog/digital input 1, full frequency
21	A/DI2	analog/digital input 2
22	NA	NA
23	SERV_EN	service enable
24	NA	NA
25	DO1	digital output 1
26	NA	NA

View on rear side of the A8

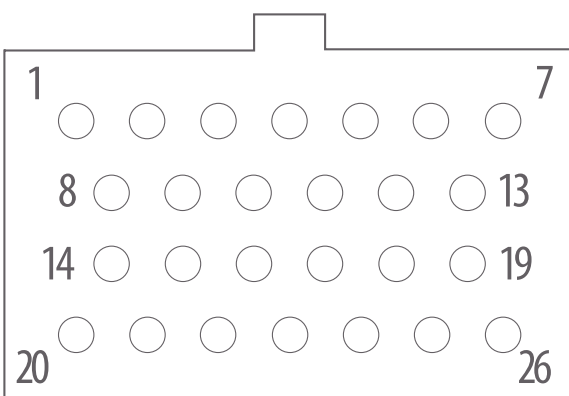

Video connector pinout

Round Connector, 5 pins, M12	
1	VidSig+
2	Mirror
3	Camera+
4	Camera -
5	VidSig GND

Ethernet connector pinout

Round Connector, 4 pins, M12, acc. To IEC 61076-2-101	
1	TD+
2	RD+
3	TD-
4	RD-

Video connector, M12, female, 5 pins, b-coded, view on rear side of the A8

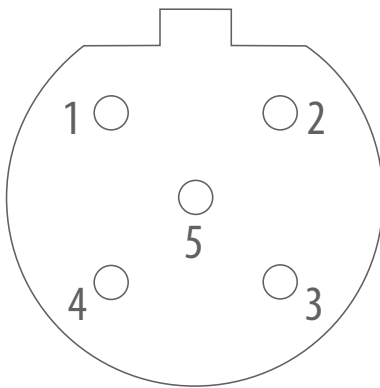

Ethernet connector, M12, female, 4 pins, d-coded, view on rear side of the A8

